











# Replacement of consumable parts

- Be sure to observe the following items for replacement of consumables.

 <b>DANGER</b>	
 <p><b>PERSON WHO FULLY UNDERSTANDS THIS MANUAL MAY PERFORM MAINTENANCE AND INSPECTION OF XPF-50.</b></p> <p>※ Otherwise, electric shock, injury, trouble, or damage may occur.</p>	 <p><b>BE SURE TO TURN OFF THE POWER BEFORE MAINTENANCE AND INSPECTION OF XPF-50.</b></p> <p>※ Otherwise, electric shock or injury may occur.</p>

 <b>WARNING</b>	
 <p><b>PUT THE REMOVED COVERS BACK IN PLACE.</b></p> <p>※ Otherwise, electric shock or injury may occur.</p>	 <p><b>WHEN MORE THAN ONE PERSON WORKS, CALL TO EACH OTHER.</b></p> <p>※ Otherwise, electric shock or injury may occur.</p>

 <b>CAUTION</b>	
 <p><b>DO NOT CLIMB ON THE XPF-50.</b></p> <p>※ Otherwise, it may result in breakage or the cover may not be able to be installed.</p>	 <p><b>DO NOT MAKE IMPACT ON XPF-50.</b></p> <p>※ Otherwise, it may have trouble or damage.</p>
 <p><b>DO NOT MODIFY THE XPF-50.</b></p> <p>※ Otherwise, trouble or damage may occur.</p>	

## 1 Replacement of Screen

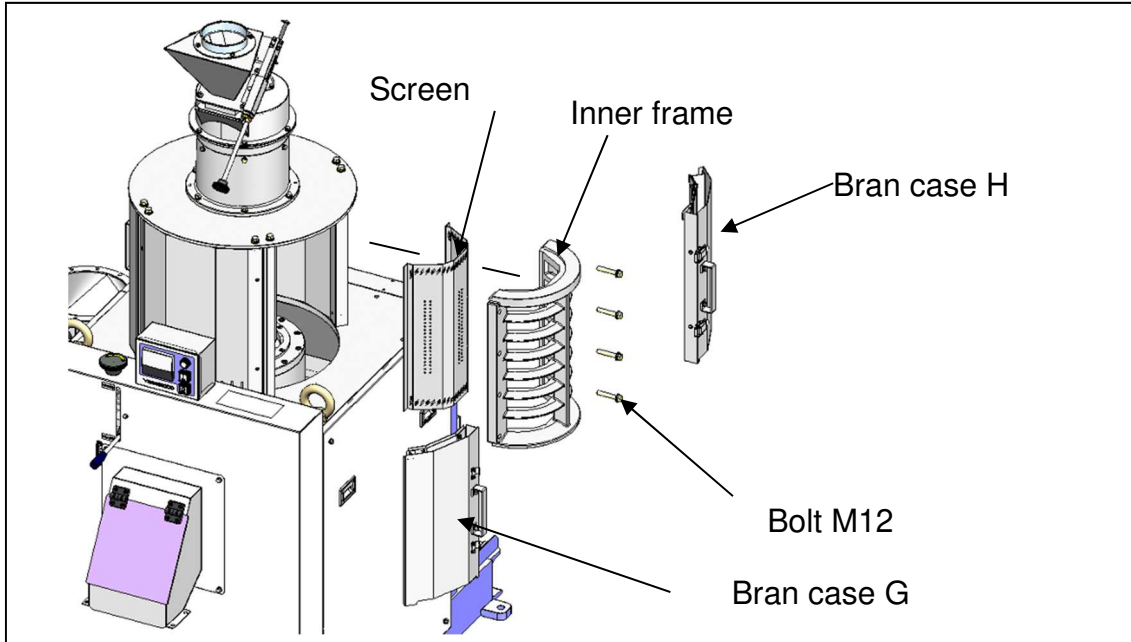

- 1** Remove bran cases G and H.
- 2** Remove the bolt M12 (8 pcs.) and take out the Inner frame and Screen.
- 3** Clean the Inner frame and screen, bran on locations where the parts are installed carefully, and install a new screen.

### NOTE

- If bran or the like are not removed, the screen is not fixed, but vibrates, and then it may cause damage of XPF-50.

## 2 Replacement of screw

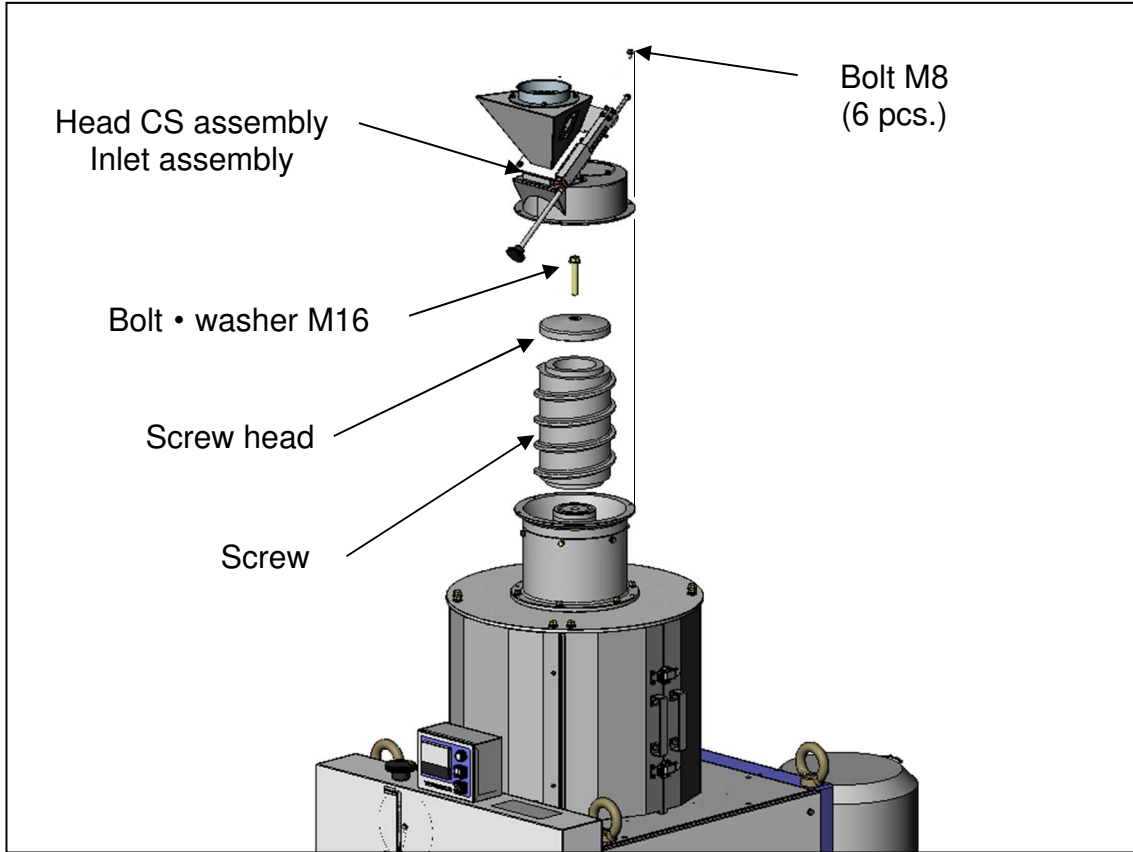

- 1** Remove the bolt M8 (6 pcs.) of the head assembly, and then remove the head CS assembly and inlet assembly.
- 2** Remove the bolt M16 and then screw head and screw.
- 3** Put a new screw into main shaft, and install the parts in the reverse steps.

### 3 Replacement of friction roll

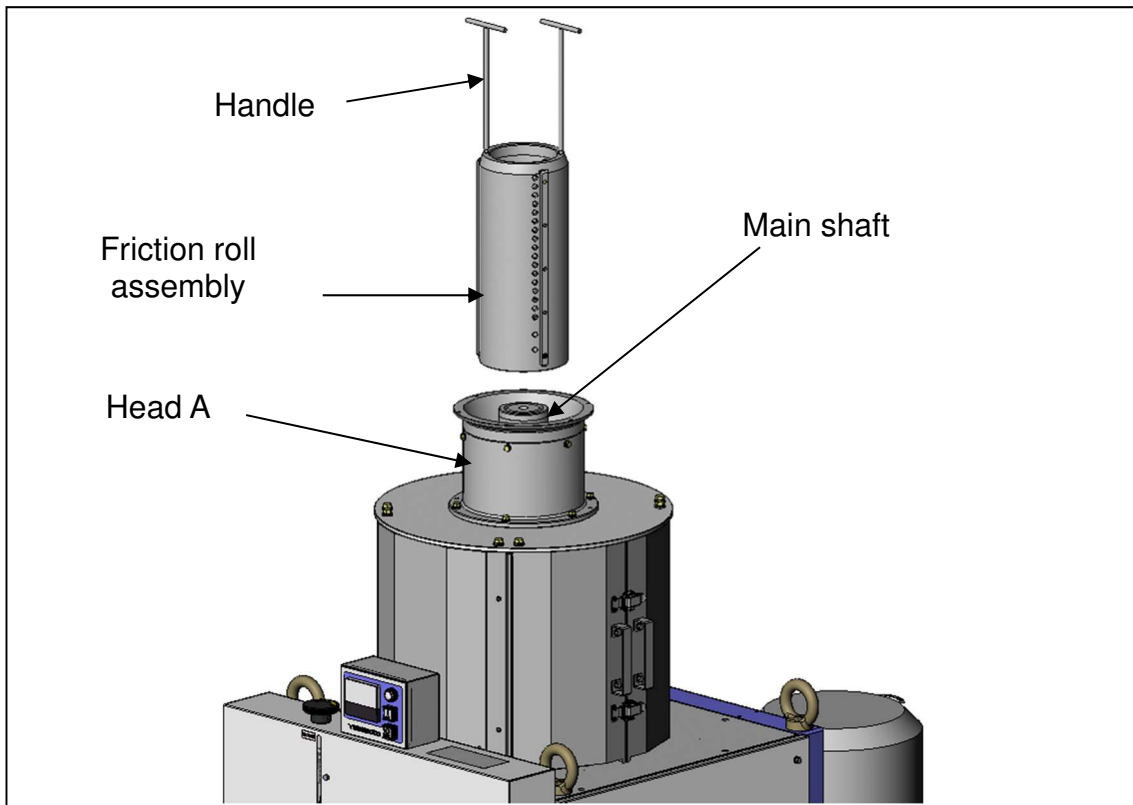

- 1** Insert the handle into a gap between head A and main shaft, and push it into two points on top face of friction roll.
- 2** Draw up the friction roll assembly by two handles without inclination.
- 3** Replace the friction roll with a new one and install the parts in reverse steps.

## 4 Replacement of inner ring

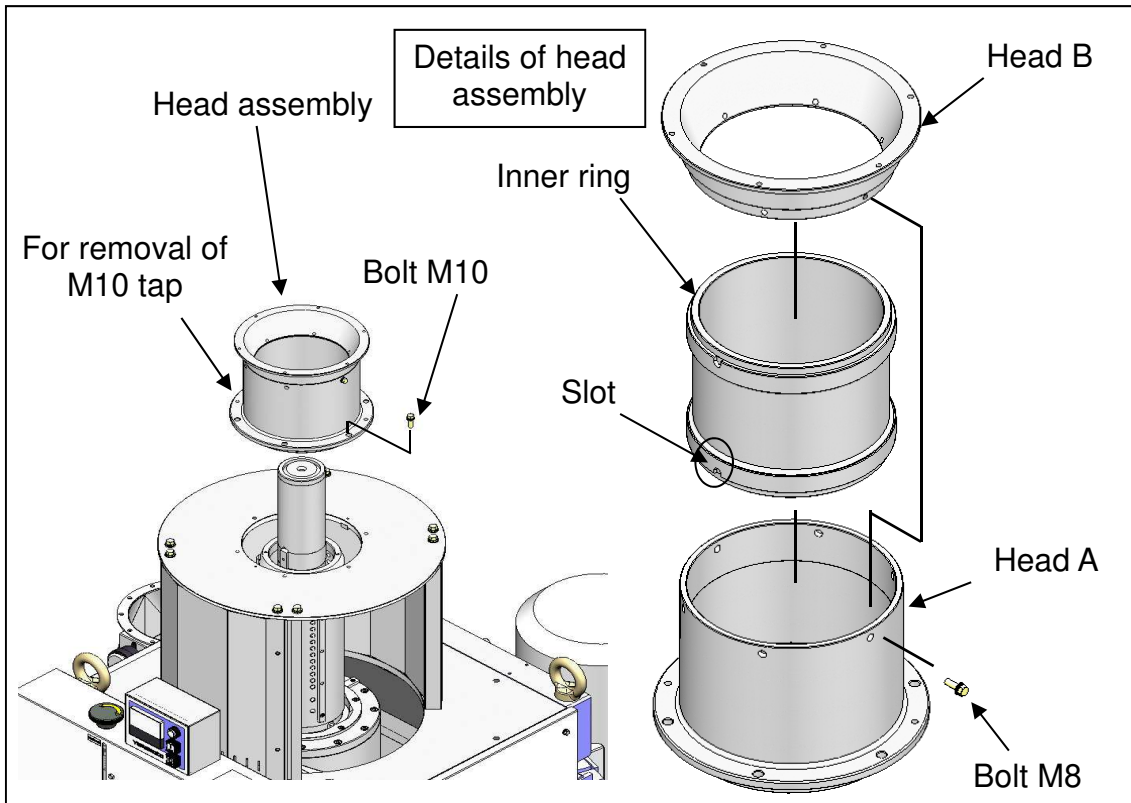

- 1** Remove the Inner frame and screen.
- 2** Remove six pieces of bolt M10 and then remove head A, inner ring, and head B assembled together (use of M10 tap for removal facilitates the removal).
- 3** Remove six pieces of bolt M8 and head B, and then take out the inner ring.
- 4** When mounting the inner ring, set the slot to the salient inside head A, and incorporate the inner ring into head A.

## 5 Replacement of projection of friction roll

**1** Remove hexagon socket head screw M6 and bolt M10 (4 pcs.) from inside of friction roll and then remove the Roll rib.

**2** Replace the Roll rib of new friction roll and install the parts in reverse steps.

