











7 Replacing consumables

- The following precautions apply to replacing consumables.

 Danger	
 <p>Maintenance and inspection of the rice milling machine must be performed by a person who fully understands this instruction manual.</p> <p>* There is a risk of electric shock, injury, failure, or damage when operated by a person who does not understand it.</p>	 <p>Always turn the power off when performing maintenance and inspection of the rice milling machine.</p> <p>* Otherwise, electric shock or injury may occur.</p>

 Warning	
 <p>Whenever a cover is removed, return it to its original position.</p> <p>* Otherwise, electric shock or injury may occur.</p>	 <p>When multiple people are working together, make sure they communicate with each other.</p> <p>* Otherwise, electric shock or injury may occur.</p>

 Caution	
 <p>Do not climb on the covers of the rice mill.</p> <p>* They may become damaged or unable to be attached.</p>	 <p>Do not subject the rice mill to severe impacts.</p> <p>* It may result in failure or damage.</p>
 <p>Do not modify the rice mill.</p> <p>* It may result in injury, failure, or damage.</p>	

7.1 Replacing consumables in the friction section

7.1.1 Replacing the screen

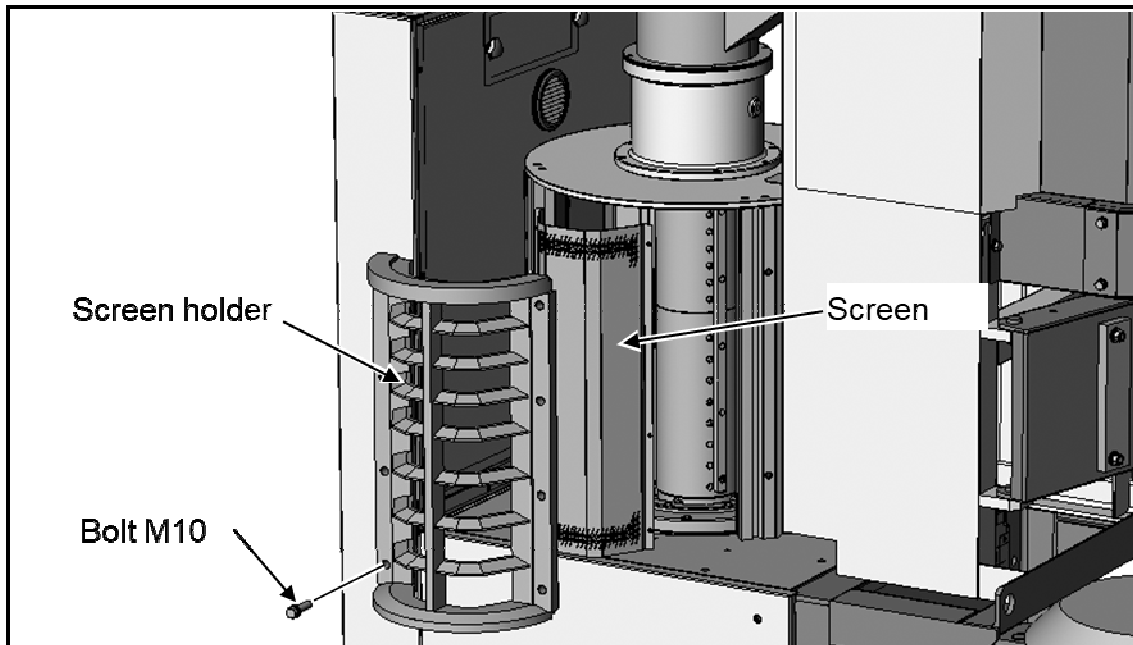

- 1** Remove bran cases G and H.
- 2** Remove bolts M10 (8 pieces) and take out the screen holder and screen.
- 3** Clean the bran from the screen holder, the screen, and places where parts attach, and then install a new screen.

Note

- If bran, etc. is not removed, the screen may not set correctly and could become damaged by vibration.

7.1.2 Replacing the screw

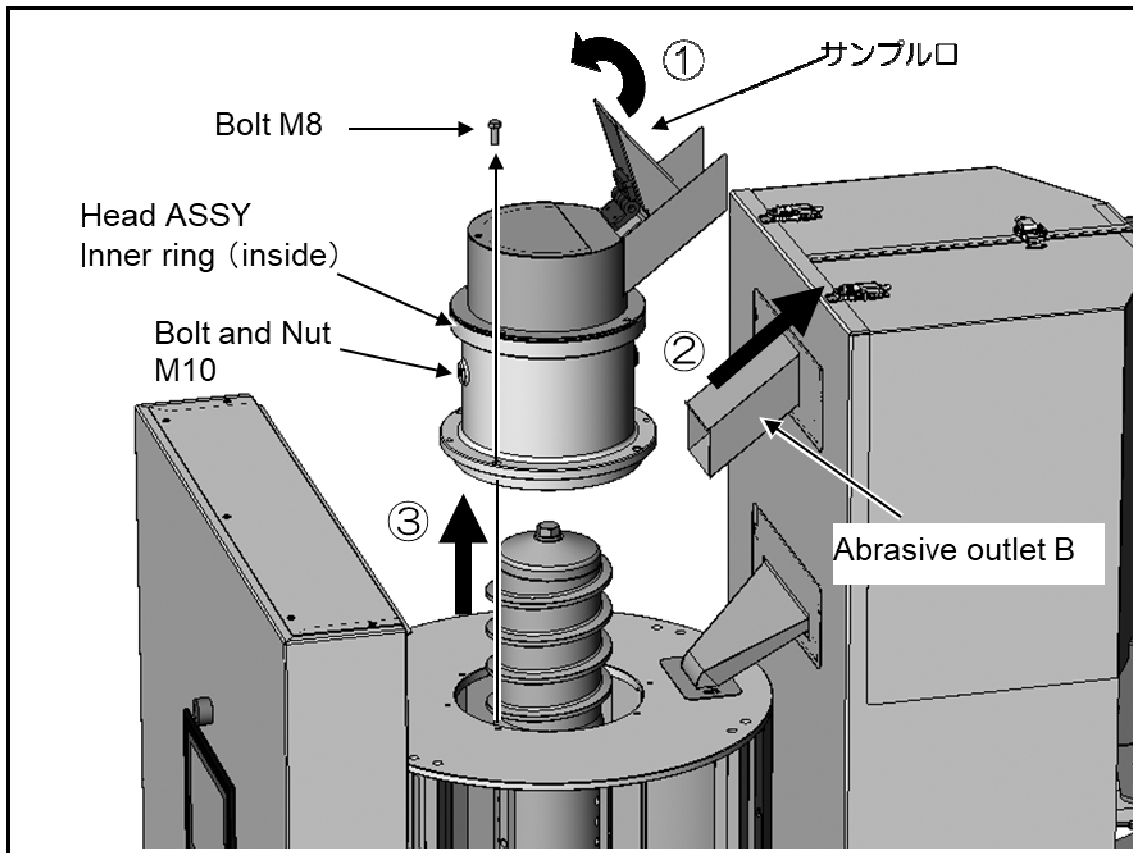

- 1** Remove bolt M8 (6 pieces) from the head assembly and remove Head C assembly.
- 2** Remove bolt M16, then remove the screw head and the screw.
- 3** Insert a new screw into the main shaft and assemble in the reverse order.

7.1.3 Replacing the friction roll

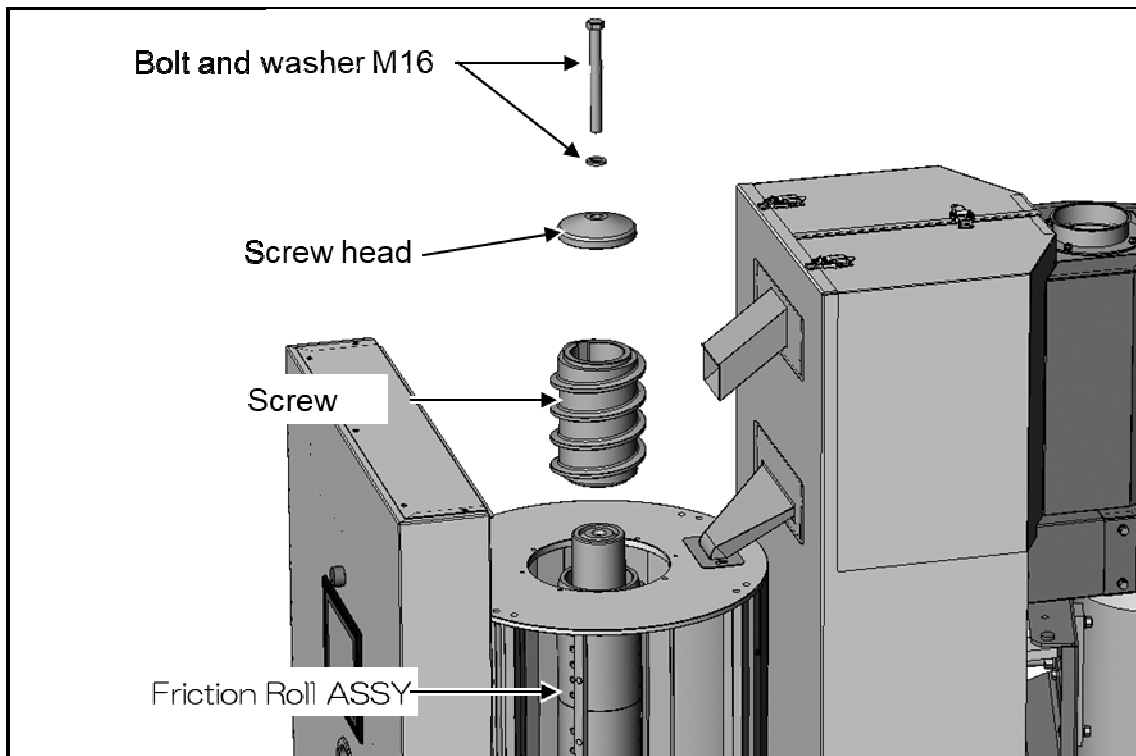

- 1** Insert the handles into the gap between Head A and the main shaft and screw them into the two locations on the upper surface of the friction roll.
- 2** Pull the two handles straight up so that friction roll assembly does not tilt.
- 3** Replace with a new friction roll and assemble in the reverse order.

7.1.4 Replacing the inner ring

- 1** Remove the screen holder and the screen.
- 2** Remove the 6 pieces bolt M10 and then remove Head A, the inner ring, and Head B as one assembly.
- 3** Remove the 6 pieces bolt M8, take out Head B, and remove the inner ring.
- 4** When attaching the inner ring, incorporate it into Head A so that the groove aligns with the convex portion of Head A.

7.1.5 Replacing the friction roll ribs

1 Remove recessed hex bolt M6 and bolt M10 (4 pieces) on the inside of the friction roller, and then remove the friction roll rib.

2 Replace with new friction roll rib, assemble in the reverse order.

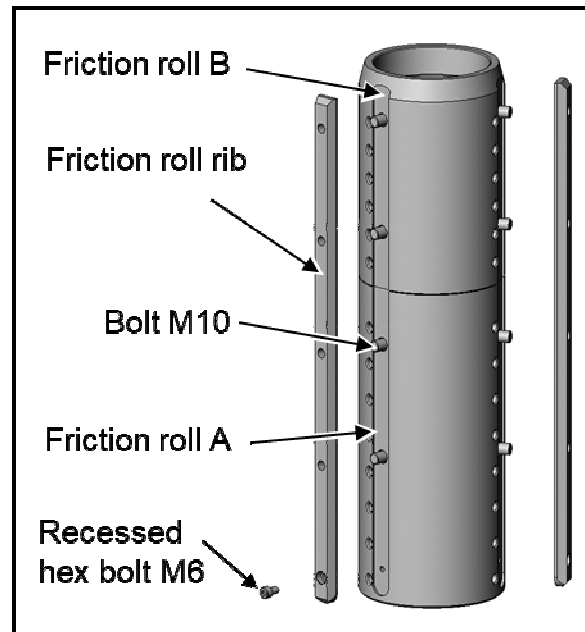

7.2 When replacing the abrasive roll(stone)

- It is necessary to dress the abrasive roll when replacing it with a new one. Conduct the Dressing the abrasive roll”.
- If the stone is not dressed while milling, bran will clog the surface of the abrasive roll and the abrasive effect will not be effective. Dressing is performed with milled rice.