









6 Inspections, adjustments, maintenance

- The following precautions apply to inspection, adjustment, and maintenance.

 Danger	
 Maintenance and inspection of the rice milling machine must be performed by a person who fully understands this instruction manual. * There is a risk of electric shock, injury, failure, or damage when operated by a person who does not understand it.	 Always turn the power off when performing maintenance and inspection of the rice milling machine. * Otherwise, electric shock or injury may occur.

 Warning	
 Whenever a cover is removed, return it to its original position. * Otherwise, electric shock or injury may occur.	 Have the dealer repair or replace the wires. * Otherwise, electric shock or fire may occur.
 Do not let children play around the rice mill. * It may result in electric shock or injury.	 When multiple people are working together, make sure they communicate with each other. * Otherwise, electric shock or injury may occur.

 **Caution**



When cleaning the discharge outlet, turn the power off and allow the heater in the discharge chute to cool.

* Otherwise, burns or injury may occur.



Do not damage, pull, or pinch wires.

* It may result in electric shock, failure, or damage.



Do not climb on the covers of the rice milling machine.

* They may become damaged or unable to be attached.



Do not subject the rice milling machine to severe impacts.

* It may result in failure or damage.



Do not modify the rice milling machine.

* It may result in injury, failure, or damage.

6.1 Regular check table

- Perform checking in accordance with the following regular check table.
The check timeline is the recommendation based on 8 operating hours per day.

Items for regular check	check period			Reference page	Comments
	Before operation	Weekly	Monthly		
Slack or damage in the abrasive motor V-belt	•			Page 6-4	
Slack or damage in the friction motor V-belt	•			Page 6-5	
Slack or damage in the raw material feed V-belt	•			Page 6-6	
Clean the outlet	•			Page 6-7	
Clean the bran removal chamber in the friction section		•		Page 6-8	At least once a week
Clean the bran duct		•		Page 6-9	At least once a week
Clean the bran removal section in the abrasive section			•	Page 6-10	At least once a month
Cleaning the hopper and the raw material feed section			•	Page 6-12	At least once a month
Clean the blower fan filter			•	Page 6-13	At least once a month
Check for damaged wires and retighten the terminal block			•	Page 6-14	At least once a month

6.2 Check, adjustment and maintenance overview

6.2.1 Slack or damage in the abrasive motor V-belt

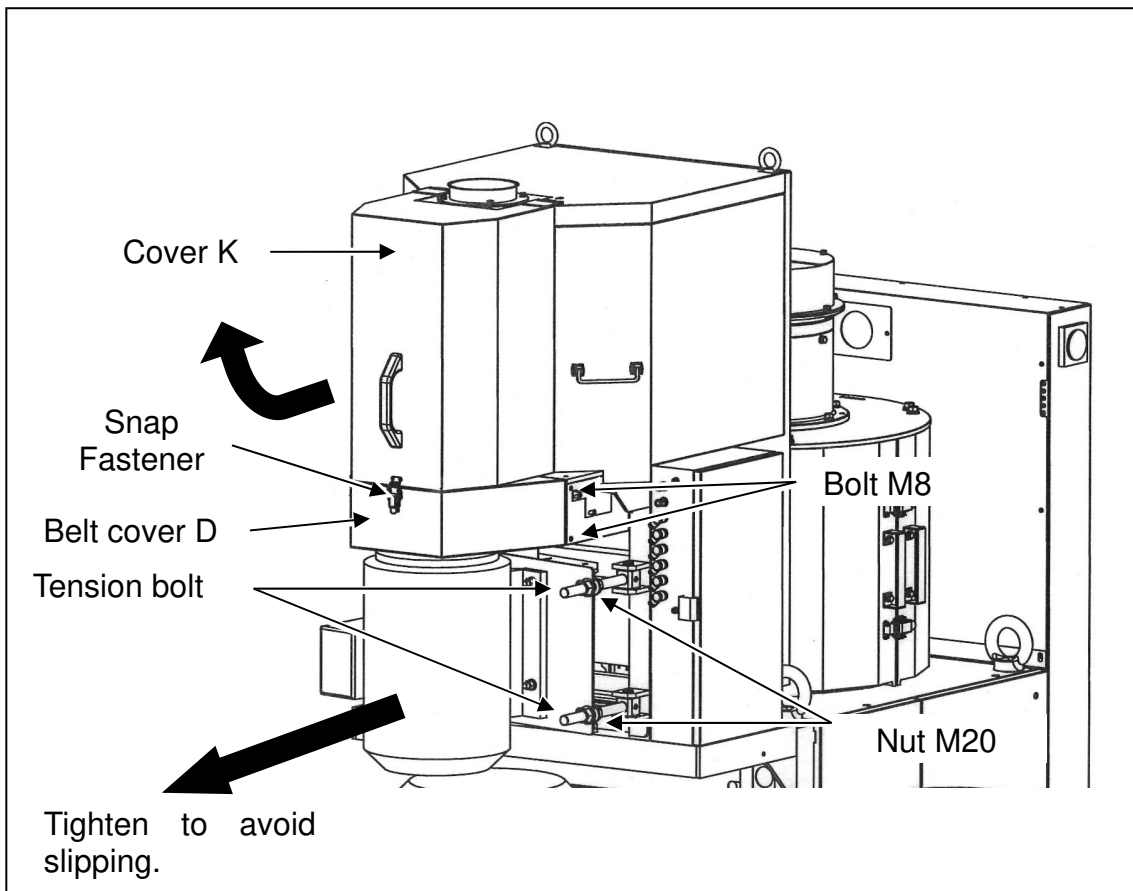

- 1** Remove cover K and belt cover D, and turn the V-belt while inspecting for slack or damage.
 - To remove cover K, unfasten the Snap Fastener and lift the handle up.
 - For belt cover D, remove bolts M8 (4 pieces) on both sides.
- 2** If there is slack, use accessory wrench 30 to loosen nut M20 on the tension bolts and tighten the belt to prevent slipping in the direction of the arrow.
If there is damage, loosen nut M20 further and replace.
- 3** Tighten nut M20 firmly.
Reassemble the removed cover to its original position.

6.2.2 Slack or damage in the friction motor V-belt

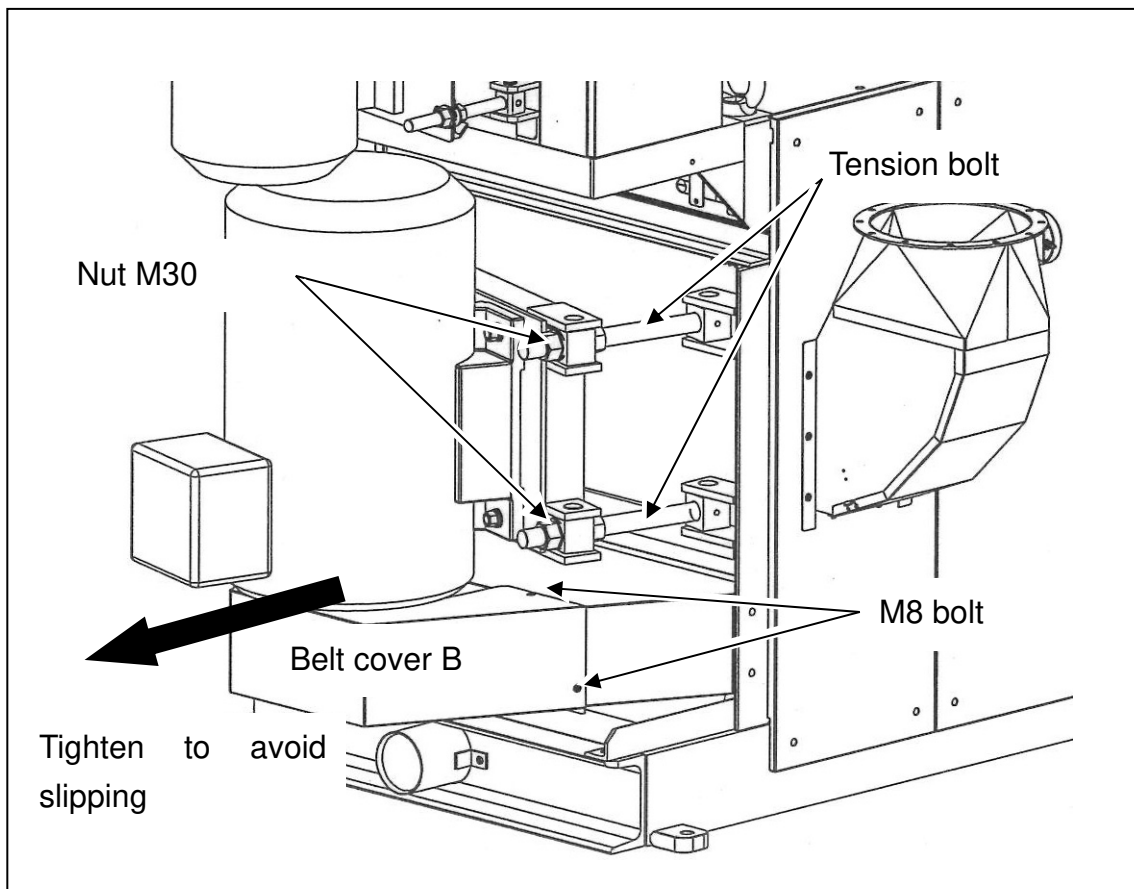

- 1** Remove belt cover B and turn the V-belt while checking for slack or damage.
 - For belt cover B, remove bolts M8 (4 pieces) on both sides.
- 2** If there is slack, use accessory wrench 46 to loosen nut M30 on the tension bolts and tighten the belt to prevent slipping in the direction of the arrow.
If there is damage, loosen nut M30 further and replace.
- 3** Tighten nut M30 firmly.
Reassemble the removed cover to its original position.

6.2.3 Slack or damage in the raw material feed V-belt

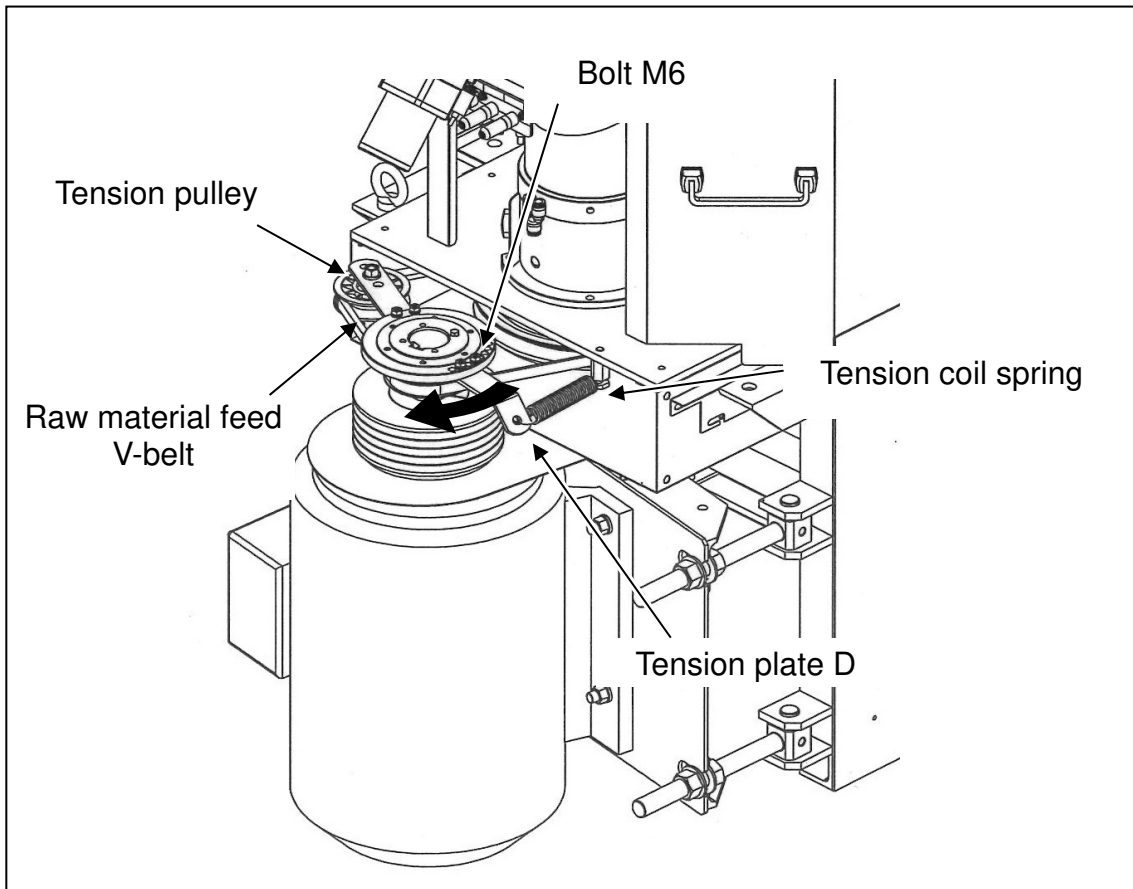

- 1** Remove cover K and belt cover D.
- 2** If there is slack, remove bolts M6 (2 pieces) that secure tension plate D, alter the mounting position in the direction of the arrow, and tighten the V-belt.
If damaged, remove the tension coil spring, release the tension pulley, and replace.
- 3** Reassemble the removed parts in their original positions.

6.2.4 Cleaning the outlet

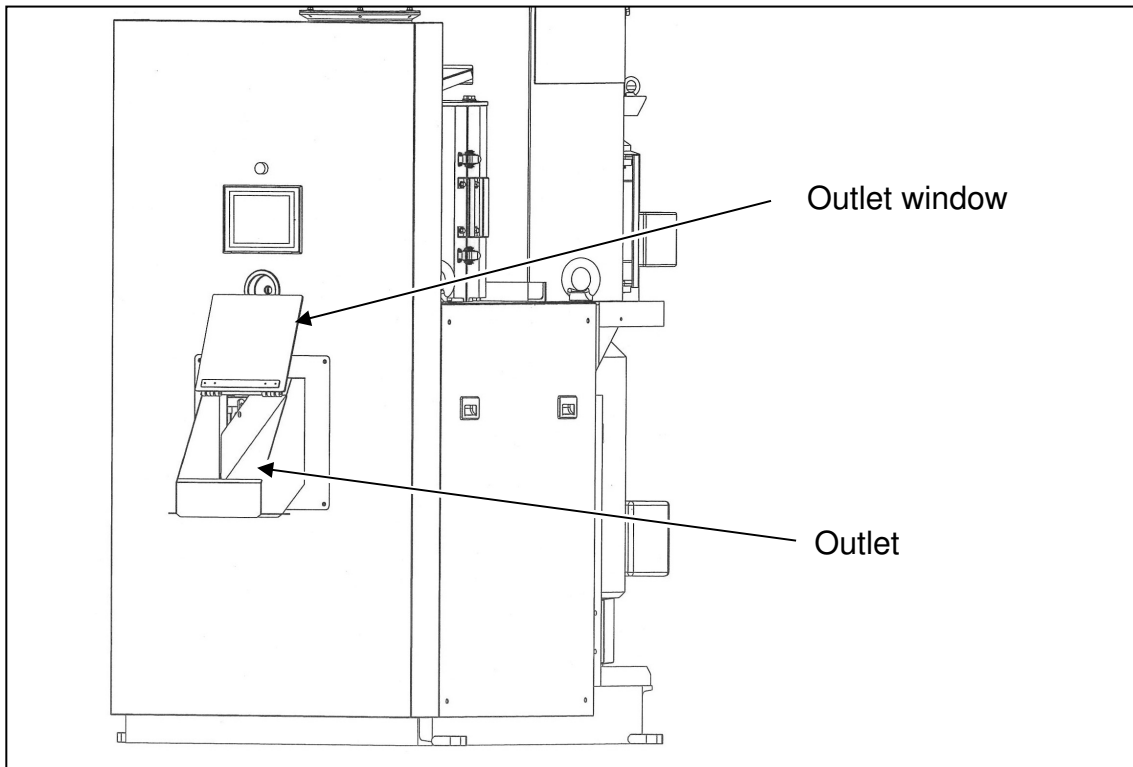

- 1** Open the Outlet window and wipe away any bran attached to the Outlet with a soft cloth.

Note

- Do not use metal scrapers or brushes.
Bran will stick easier to a scratched surface.

6.2.5 Cleaning the bran removal chamber in the friction section

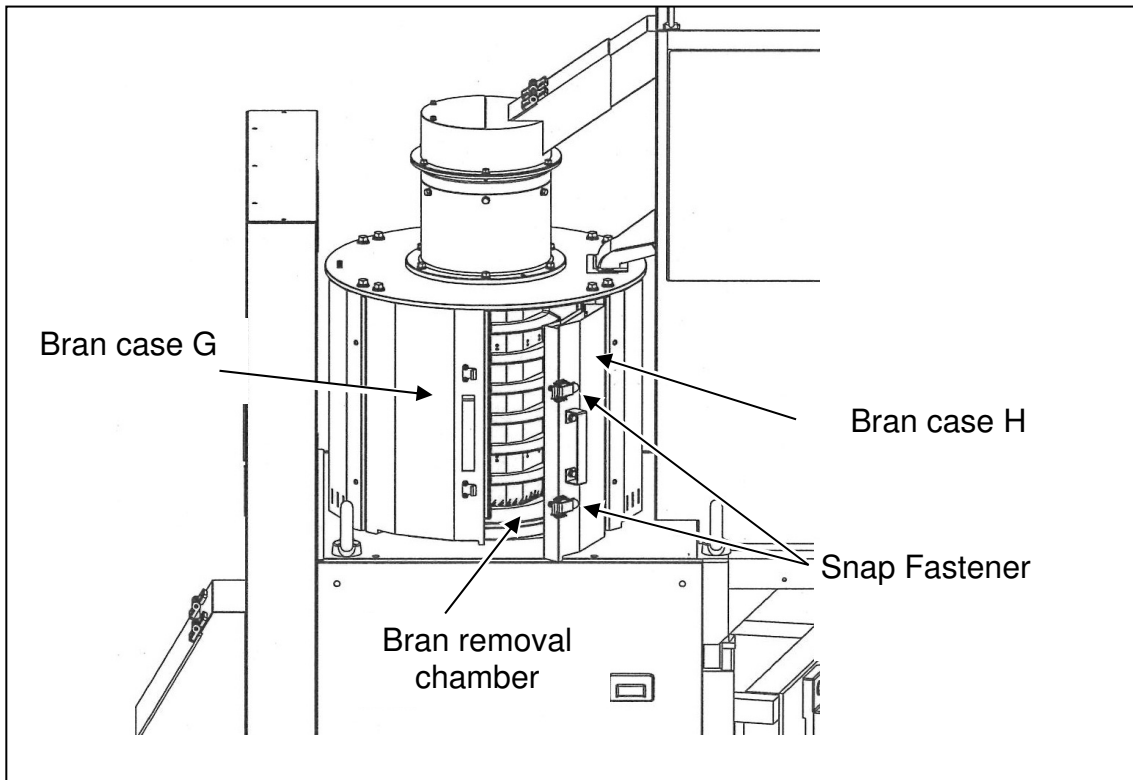

- 1** Open the Snap Fastener, remove bran case G and H and wipe away any bran inside the bran cases.

Note

- Do not use metal scrapers or brushes.
Bran will stick easier to scratched surface.

- 2** Using an blow gun or vacuum cleaner, clean any bran on the bran removal chamber, the screen holder, and the screen.
 - When using a blow gun, start the bran removal equipment (bag filter, etc.) at the set static pressure.

- 3** Reassemble bran removal case G and H in their original positions.

6.2.6 Cleaning the bran duct

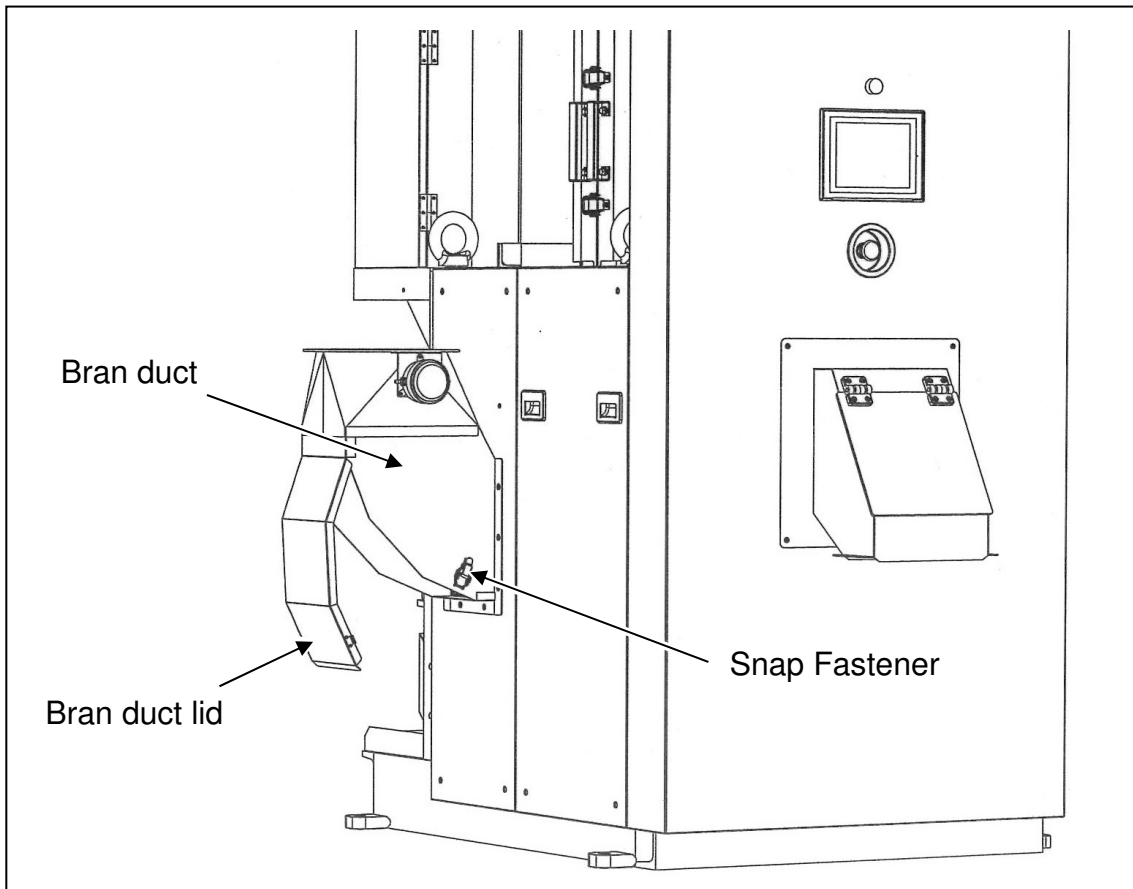

1 Unfasten the Snap Fastener (2 pieces), remove the bran duct lid and wipe away any bran on the inside of the bran duct lid.

2 Use a blow gun or vacuum cleaner to clean any bran on the inside of the bran duct lid.

Note

- Do not use metal scrapers or brushes.
Bran will stick easier to a scratched bran duct or bran duct lid.

3 Reassemble the bran duct lid to its original position.

6.2.7 Cleaning the bran removal chamber in the friction section

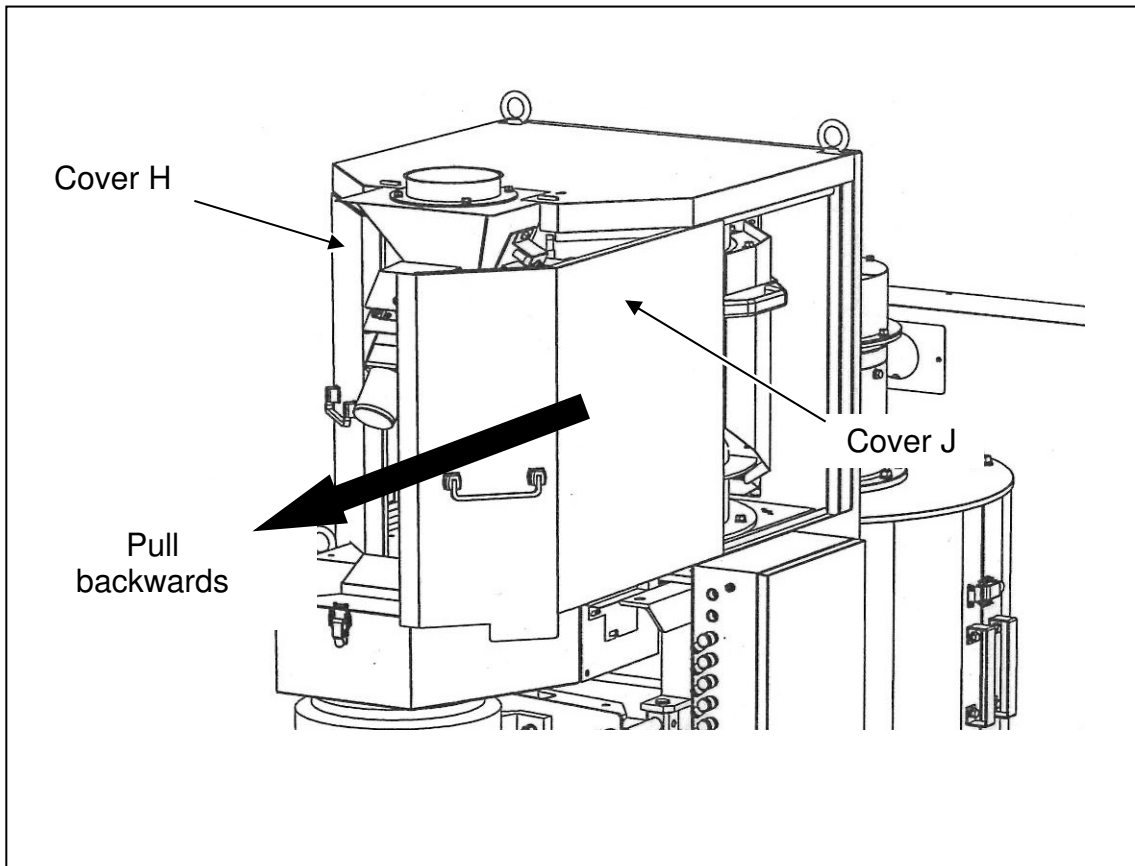

1 Remove cover K.

2 Remove cover H and cover J.

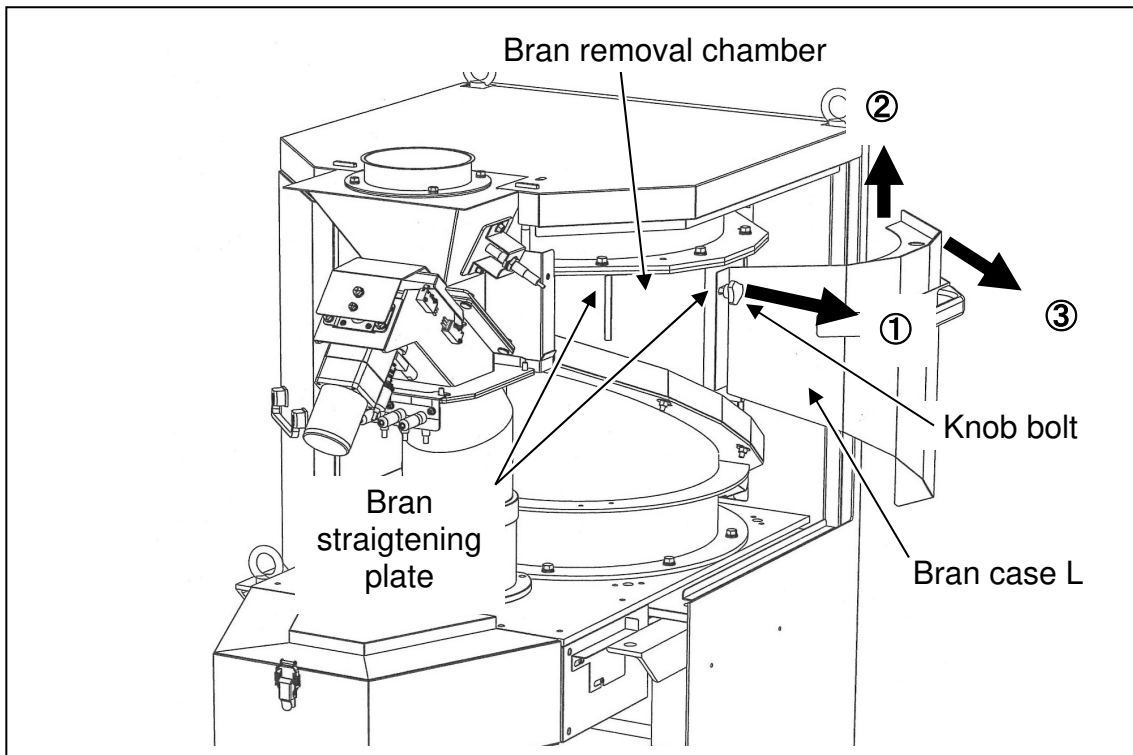

3 Remove the knob bolt and remove case L and case K (opposite side) following the order shown in the Figure, and then wipe away any bran on the inside of the bran removal case.

4 Use a vacuum cleaner to clean any bran in the bran removal room. Wipe away any bran on the bran straightening plate.

Note

- Do not use metal scrapers or brushes.
Bran will stick easier to a scratched bran case or bran straightening plate.
- Please do not bend the bran straightening plate.
If you bend them, bran will clog easily.

5 Reassemble the removed parts in their original positions.

6.2.8 Cleaning the hopper and the raw material feed section

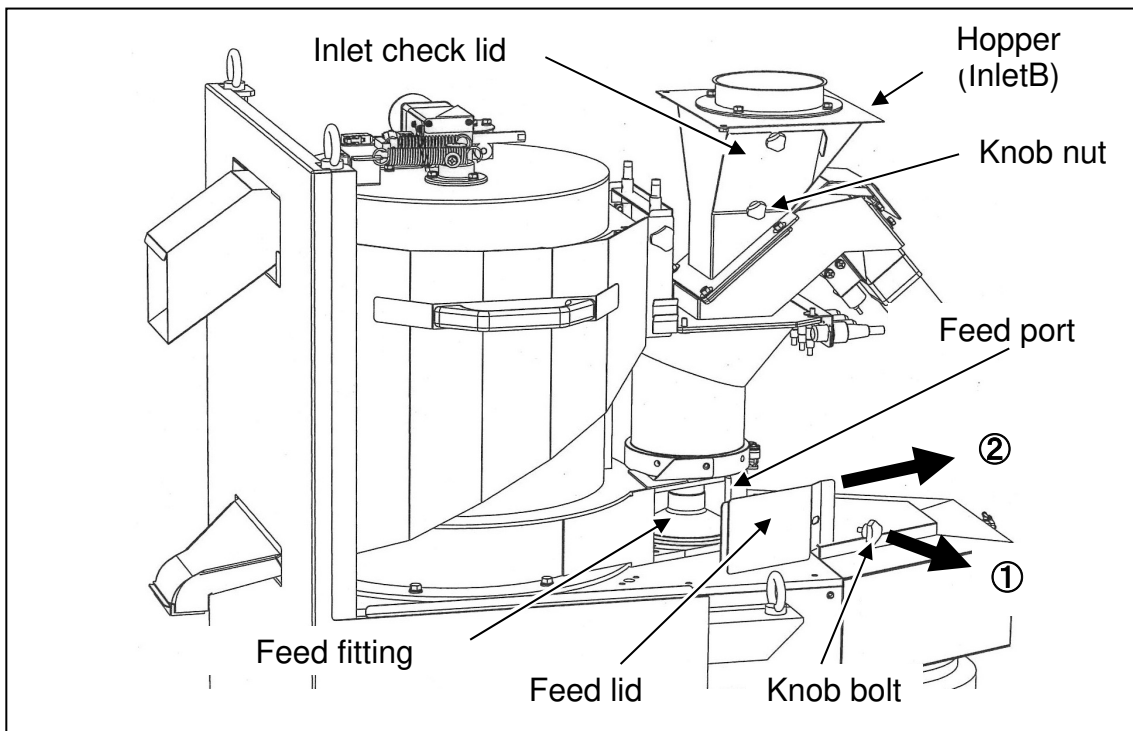

- 1** Remove covers H, J, and K.
- 2** Remove the knob nuts, remove the inlet check lid, and remove any foreign objects (bran balls, etc.) in the hopper.
- 3** Remove the knob bolt and remove the feed lid feed port following the order shown in the Figure, and clean any brown rice residue inside of the feed and the feed port.
- 4** Ressemble the removed parts in their original positions.

6.2.9 Cleaning the blower fan filter

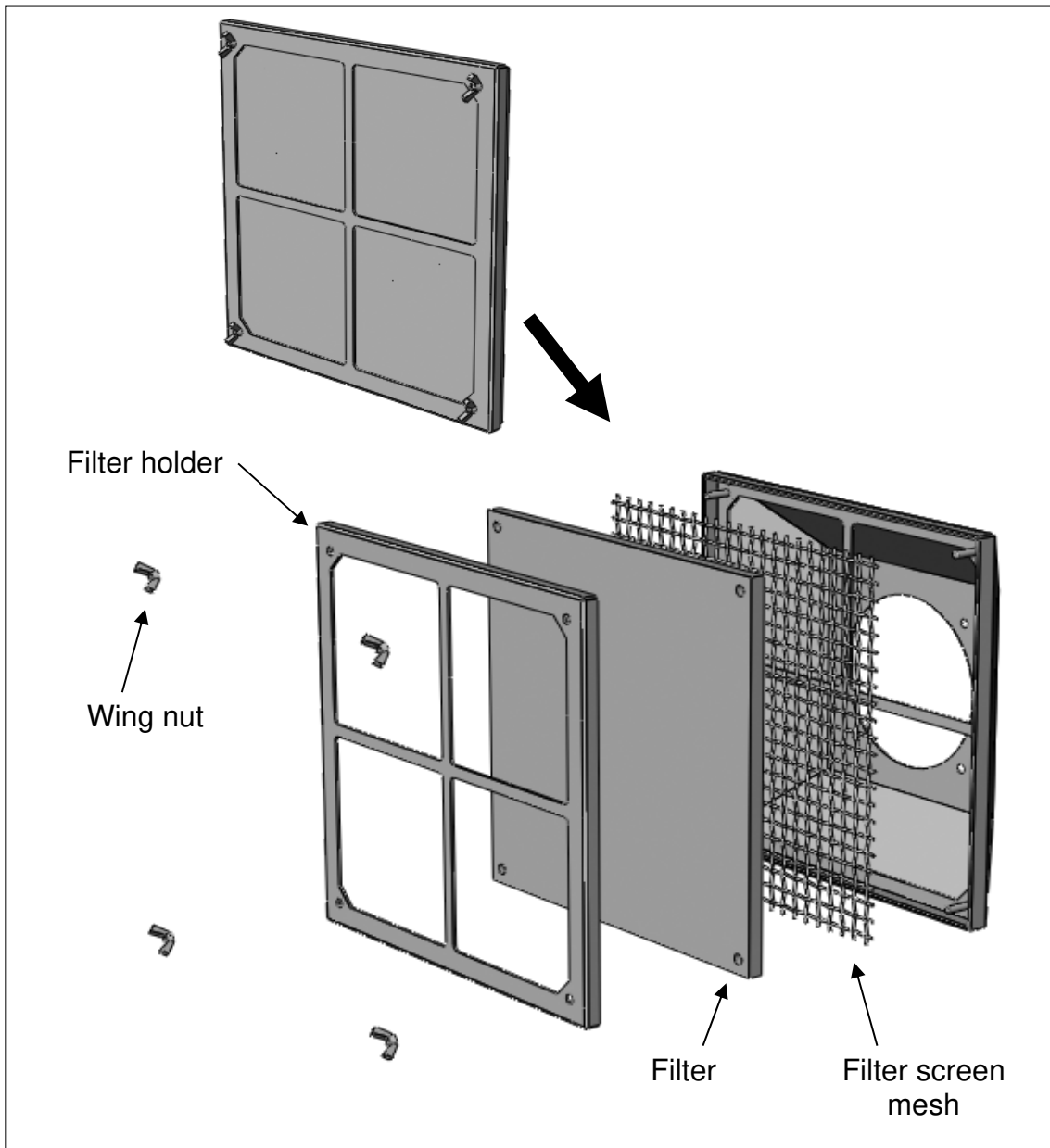

- 1** Vacuum the dust on the filter with a vacuum cleaner. Alternatively, remove the wing nuts (4 pieces), remove the filter, and clean it with a blow gun.

- Replace it when it is damaged or when the dust cannot be removed.

- 2** Resemble the parts to their original positions.

Note

- Do not use a blow gun on the filter while the filter is attached to the blower fan.

6.2.10 Checking for damaged wires and retightening the terminal block

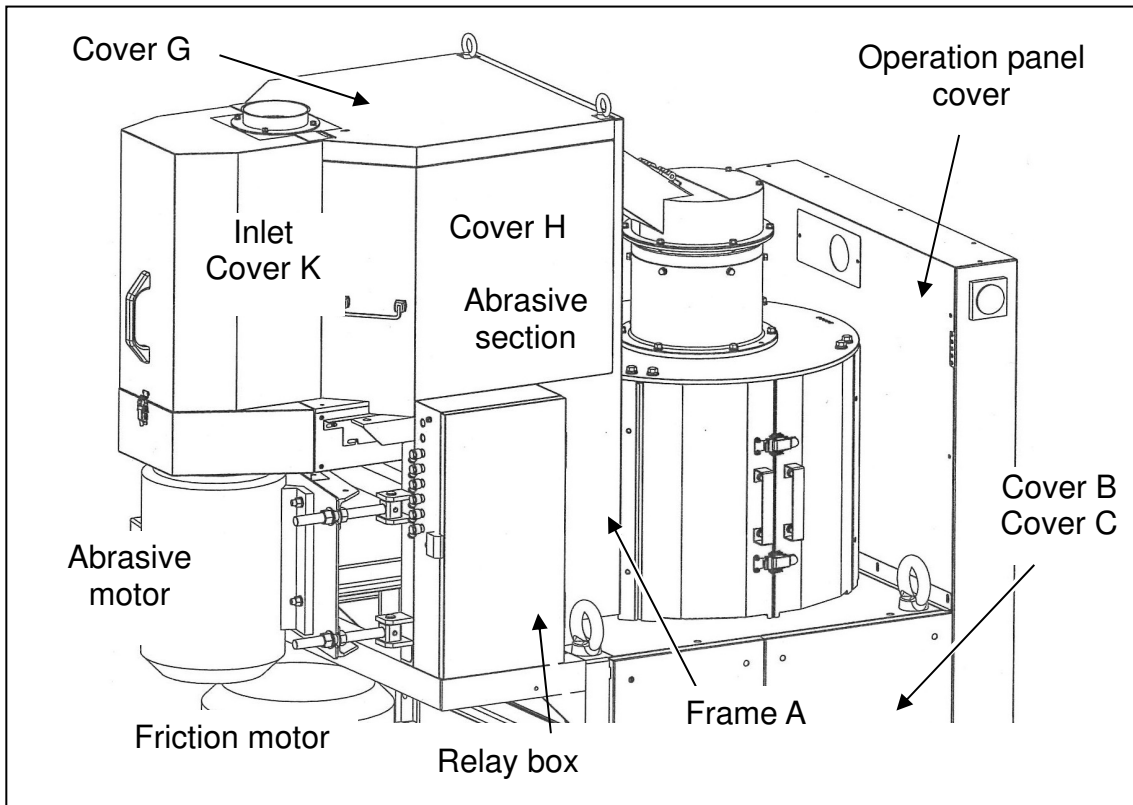

- 1** Open the relay box door and check the relay box for damaged wires. Tighten the terminal block.
- 2** Remove the operation panel cover and check the internal wires for damage. Tighten the terminal block.
 - Remove bolts M6 (6 pices) from the operation panel cover.
- 3** Remove the covers on both sides of the rice mill machine (covers B and C) and inspect the internal wires for damage.
 - For covers B and C, remove the four corner bolts M8 (4 pices).

- 4** Check the wires inside frame A for damage.
- It is the wire that comes out from the back of the rice mill machine and enters the relay box, supply area, and abrasive section.

- 5** Remove covers G, H, J, and K and check for damage in the wires in the inlet and abrasive section.
- Remove the top two knob bolts securing cover G and remove cover G.

- 6** Check the abrasive motor and the friction motor wires for damage.

- 7** Reassemble the removed parts in their original positions.

6.3 Adjusting the rice sensor

- The rice sensor detects whether brown rice is present. If the mounting position is wrong, the rice mill will not stop automatically, or may malfunction by stopping automatically during the milling process, etc.

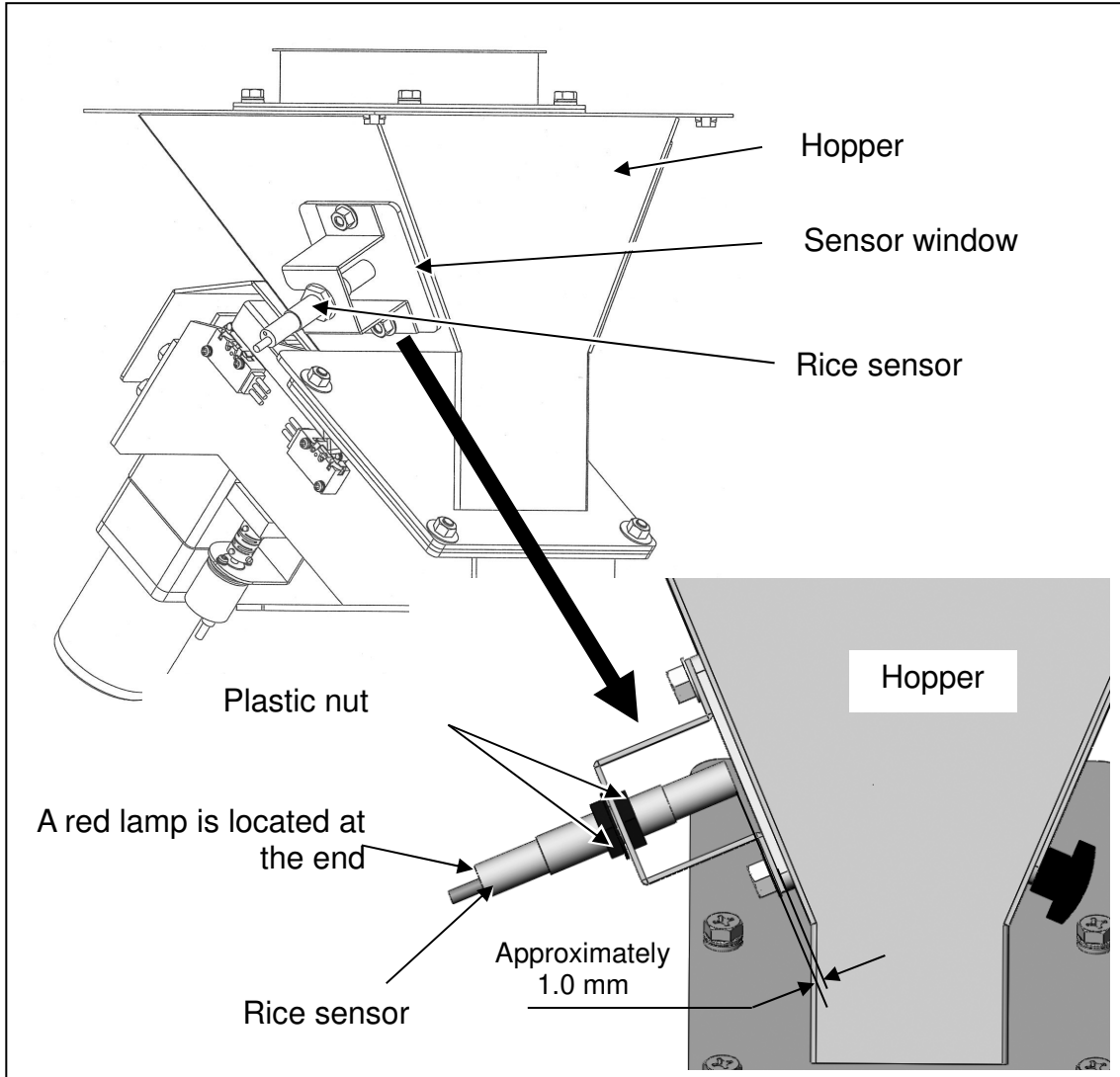

1

Loosen the plastic nuts on the raw material sensor and set the sensor approx. 1 mm with the sensor window.

- Check whether the **Rice** light in the <Milling operations> screen indicates that materials are present in accordance with the presence or absence of raw materials.
- Increasing the distance from the sensor window will impede detection.

6.4 When rice is stuck

- If rice becomes stuck, remove it using the following procedures.

6.4.1 When rice is stuck in the abrasive section

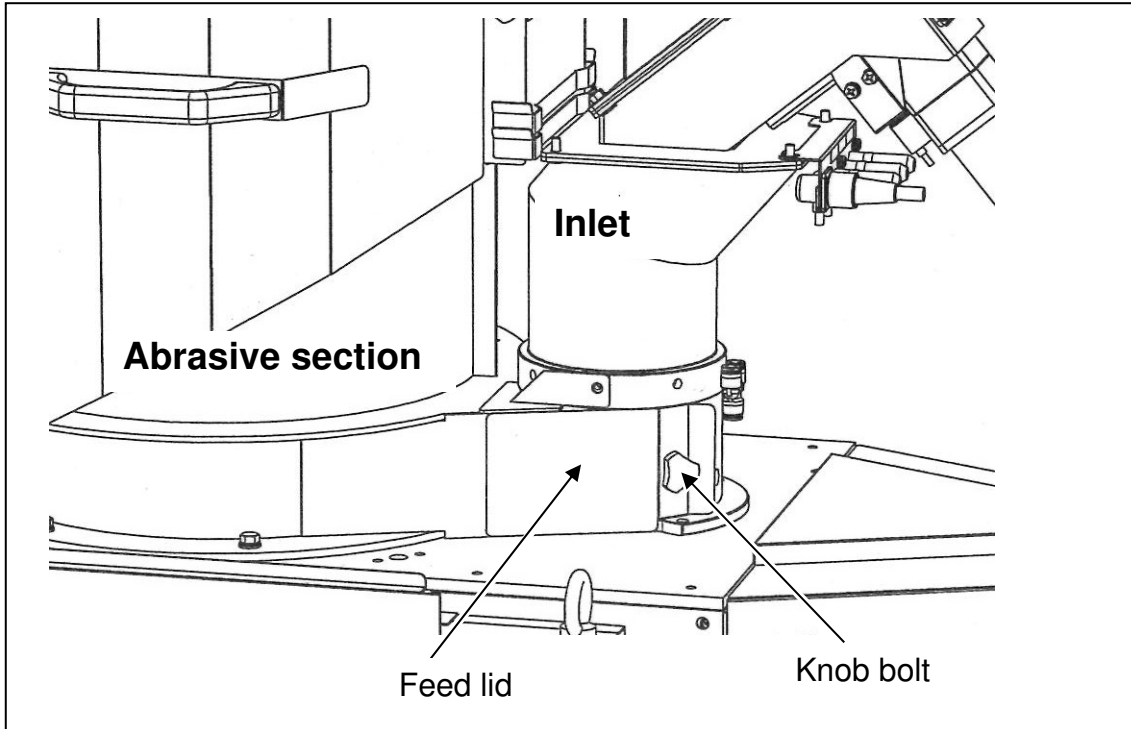

- 1** Check whether the inlet is closed.
If open, press the **Inlet close** button to close it.
- 2** Turn the power off and remove covers H, J, and K.
- 3** Open the feed lid and remove the rice from the inlet and the abrasive section.
 - Remove the knob bolts (2 pieces) from the feed lid.
 - After removing the rice, reassemble the removed parts in their original position.
- 4** Reset thermal relay THR3 on the standard power board.
 - Refer to page 6-18 “6.4.3 Thermal relay reset”.

6.4.2 When rice is stuck in the friction section

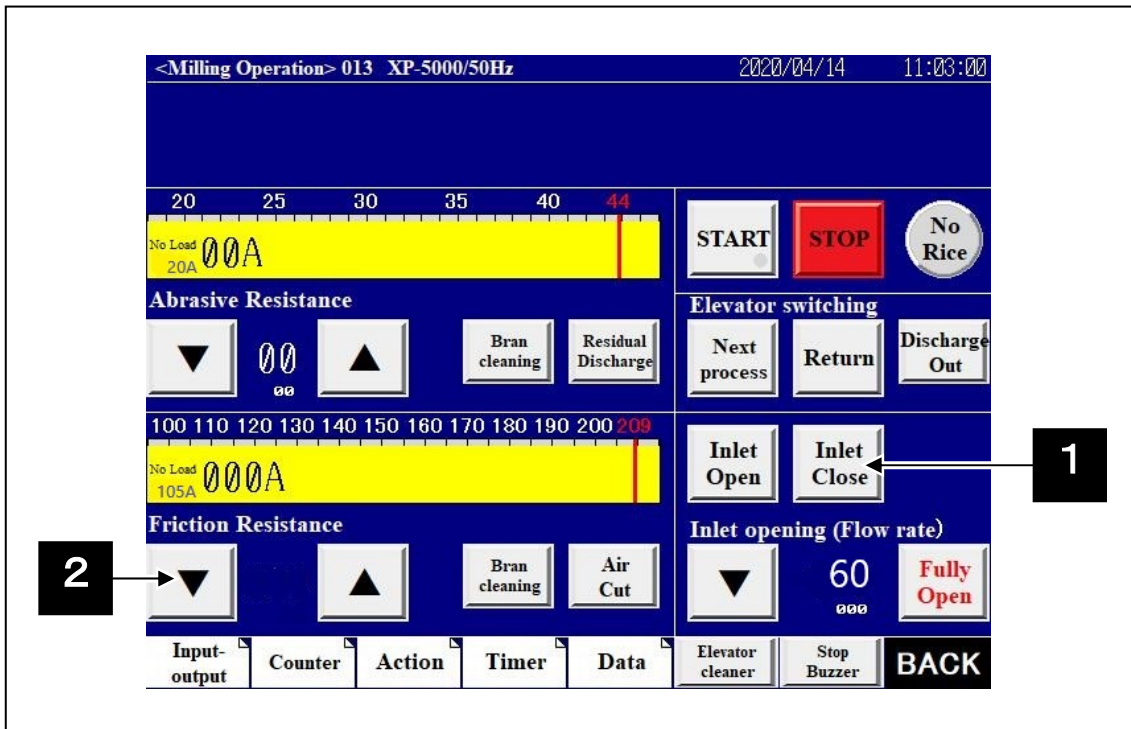

1 Check whether the inlet is closed.
If open, press the **Inlet Close** button to close it.

2 Press the friction resistance **▼ (decrease)** button and set friction resistance to 0.

- Rice is discharged from the friction area.

Note

- If the rice is not discharged, turn the power off and turn the V-belt of the friction motor to discharge the rice. (Refer to **1** on page 6-5 “6.2.2 Slack or damage in the friction motor V-belt”)

If the rice is still not discharged, remove the screen.

3 Reset thermal relay THR2 on the standard power panel.

- Refer to page 6-20 “6.4.3 Thermal relay reset”.

6.4.3 Thermal relay reset

- After removing the stuck rice, reset the thermal relay.
- The figure below provides a description of the optional standard power panel. If you are not using the standard power panel, follow the handling instructions for the thermal relay you are using.

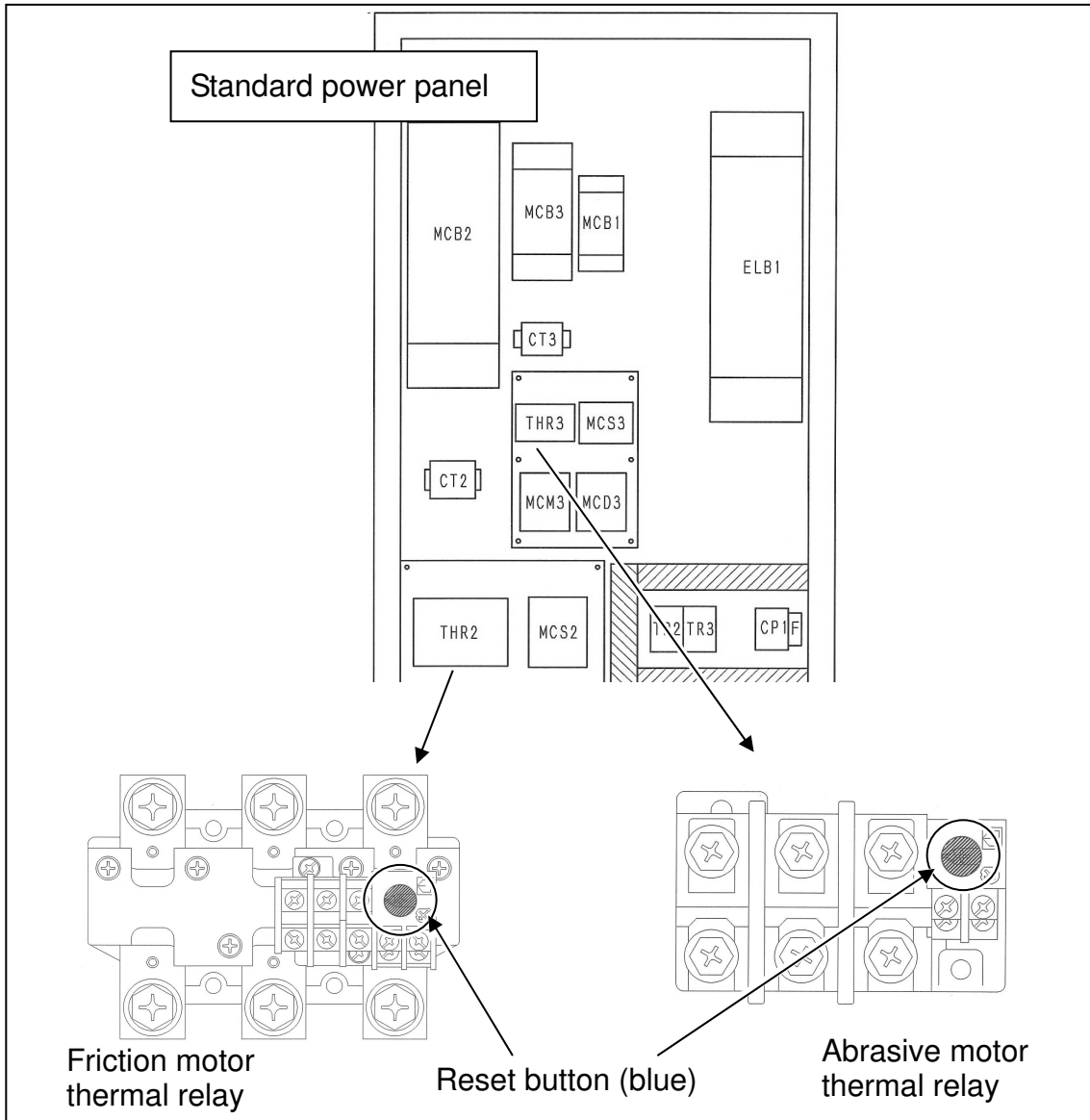

1

Turn the power off and press reset button THR2 when the friction motor is clogged (the friction motor has thermally tripped) and press reset button THR3 when the abrasive motor is clogged (the abrasive motor has thermally tripped).

- When reset, each **Motor thermal** light on the touch panel will turn off.